

# How to Make Your Own Radiovisor

Radiovision

This is the fifth in a series of articles prepared especially for Science Service by one of the pioneer inventors in movies and television. Copies of the SCIENCE NEWS-LETTER containing the first four installments may be obtained from Science Service for \$.15 each.

By C. FRANCIS JENKINS

The radiovisor is now ready for the motor.

Almost any small motor will do, A. C. or D. C., to suit your house current, and 1/20 h. p. is ample.

On the shaft of the motor put the hub with nut and flanges, shown in illustration, between which a rubber driving flange is clamped. This driving flange is cut from a punctured or blown-out inner tube automobile tire.

First cut a center hole 5/16 inch diameter. Cut the disc out roughly and put it on the motor hub. Start the motor and touch the disc with a pencil about 1 1/2 inches from the motor shaft center. Now take the rubber disc off and with sharp scissors cut on the pencil line, which will give you a 3-inch rubber driving disc when clamped between the flanges of the motor hub and the nut tightened.

Do not use more than two friction discs together, cut from the average thickness of inner tubing; one thickness is usually best. The disc will chatter a little at starting, but the synchronism is more easily held with a thin disc after it is up to speed.

The motor hub detailed in the drawing is best made in a machine shop. But a less permanent driver can be made by fastening the rubber with shellac to a wooden disc slipped

tightly on the motor shaft.

The motor and drive are now ready to attach to the radiovisor.

Set the motor on the motor board, and fasten it in such a position that the rubber disc bears against the back of the scanning disc about 2 1/2 inches from the axis of the scanning disc, when the motor board is midway of its possible movement. If a paper scanning disc is used it may be necessary to put it between two 10-cent store toy talking machine records for the driving disc to bear against.

Synchronism is attained by moving the motor board to or from, the center of the scanning disc, by the screw S shown in the illustration. This should be a long-shank round-head 1/4-inch machine screw with nut, or a square-

headed bolt about 3 1/2 or 4 inches long. Solder into the slot of the screw a wing to facilitate rotating it, or into a hacksaw slot in the bolthead. Put the nut in the 5/8-inch hole of the guide strip on the bottom of the motor board, and screw the bolt into it through the hole provided therefor, which will leave the wing-nut at the end of the baseboard readily accessible for moving the motor to and fro.

Don't use a rheostat in circuit with the driving motor; let it run at its natural period, the speed for which it was designed; synchronism is attached by changing the distance of the motor from the center of the scanning disc, *not by changing the motor speed.*

Science News-Letter, October 13, 1928

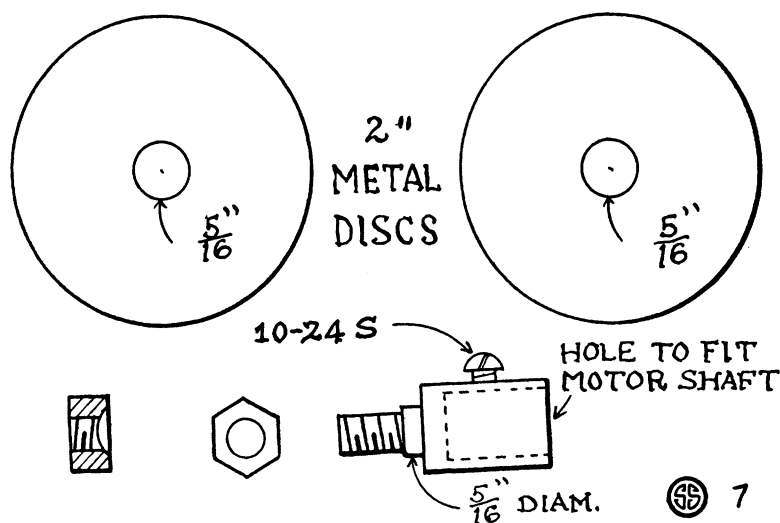

## Aqueous Intoxication

Physiology

Intoxication by water is declared possible by Dr. Oliver Kamm of Detroit. Whether water is a harmless beverage depends upon the amount imbibed and the cellular constitution of the imbiber. The four glasses a day recommended by one of the insurance companies which has taken on the task of protecting the people's health may be too heavy drinking for a few individuals, while others may drink several gallons of water a day without slaking their abnormal thirst. Dr. Kamm has found that the amount of water demanded is dependent upon the activity of the posterior portion of the pituitary gland at the base of the brain. This little organ secretes two

kinds of hormones, or regulators of the human system, so much alike that they have been called "the pituitary twins," but have recently been separated and are now employed in medicine for different purposes. They are distinguished as A and B, or on account of the traditional fondness of scientists for Greek, as alpha and beta. The beta secretion regulates the water supply. The portly person who persists in putting on weight in spite of cutting down his diet and drink may be suffering from an excessively active pituitary gland or from the undue sensitivity of his tissues to the secretion. He is called "fat" by his friends or his enemies, but he may be

merely water-logged. On the other hand, the scrawny man, who remains lean however much food and water he takes, may have the opposite defect of pituitary action and be suffering from desiccation. This same beta hormone aids the frog in changing his skin color to suit his surroundings as a kind of camouflage. A frog in his light-colored costume turns dark on being treated with a minute dose of the hormone, because this expands the black cells in his skin. Dr. Kamm suggests that this secretion may save life in the case of extensive body burns, since the danger here is from the undue drying of the tissues.

Science News-Letter, October 13, 1928