

# of the future

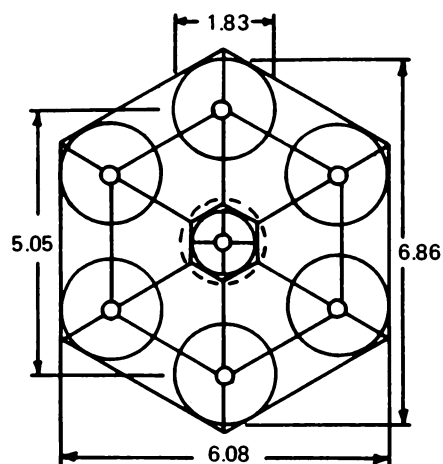

MMT layout, dimensions in meters.

The project, in Sanger's words, is "tightly funded." He figures the total actual outlay will be about \$4 million. If one counted in the value of the donated optics, the cost would come to about \$6 million to \$6.5 million. To build a single-mirror 176-inch telescope would cost about \$15 million and prices are rising.

The MMT will be a versatile instrument. Throwing all six images together will give the resolution of a 72-inch telescope in an image six times as bright. The six images can be separated and made to lie side by side so that different observations may be made at the same time on the same star. Any combination of lesser number than six can be used together as desired. Both infrared and visible-light observations are contemplated.

In the somewhat more distant future Sanger hopes to overcome the difficulties involved in coordinating the phases of the different images, so as to use the MMT as an interferometer (something that is commonly done with radio telescope arrays). This could increase the resolution to the theoretically possible equivalent of a 270-inch single telescope. The difficulties are many and involve such things as scintillation due to atmospheric turbulence and to variations in barometric pressure, as well as others, which the radio astronomers didn't have to bother with. If this succeeds, then the MMT and others like it will be able not only to see objects as faint as those big single telescopes can see, but also to detect detail as fine or finer. Sanger expects it will be 1980 before the MMT is an interferometer. He is not yet sure exactly how it will be done, but he has high hopes: "My Ph.D. thesis is supposed to solve the problem." □

august 18-25, 1973

## A project to last half a century:

### Measuring the proper motions of stars

In a room on the Santa Cruz campus of the University of California stands the Lick Observatory's automatic plate measuring machine. The machine compares photographic plates of the sky taken at intervals of decades to measure the motions of the stars. (Contrary to the term "fixed stars," which astronomers don't like to use, the stars do move. The component of their motion that changes their position in the sky is called proper motion.)

The Lick proper-motion study began 26 years ago and is expected to continue to the end of the century. Some 1,246 plates are required to cover the entire northern sky and the southern sky down to minus 30 degrees declination, as far south as can be seen from Lick's location. Each plate represents an exposure of two hours length. The first set of plates was begun in 1947; the second was begun in 1967 and is still unfinished; the third is planned for the 1990's.

There is thus an enormous span of time involved in a work of this kind. The people who began it knew that they would get no results at all for 20 years. The really good results are not expected until the third series of plates is completed. Thus individuals who gave part of their lives to the work might not live to see the results. Indeed, one astronomer remarks that some of those who worked on the first series are already gone. In most scientific endeavors a person setting up an experiment expects to see results in a few years at most. The only parallel to the proper-motion situation the astronomer could think of is in molecular biology where the unraveling of a complicated molecule can take a lifetime.

Yet proper-motion studies are a bread-and-butter issue in astronomy. They must be constantly done to keep star maps up to date. In earlier times the comparison of plates was done by hand and eye. The technique, known as blinking, is similar to an amusement park peep show. One looks at two plates of the same area of sky in rapid succession. A change in a stellar position will be detected as an apparent motion of the image.

Now the blinking is done by the machine. It can locate star images on the plate with an accuracy of two microns. When a position is determined a human operator intervenes to punch the information on a card to feed to a computer. The motion is measured relative to the background of galaxies, which, though

they too move, are "fixed" compared to stellar motions. According to Lloyd Robinson of Lick, within a very short time the computer should be connected to the measuring machine and take the information directly. Another place where automation is desired is in the telescope. Over the two-hour exposure time, says Robinson, "the telescope follows the star [in the center of the field], but not well enough." A human operator must watch over it for fine adjustments. An automatic guide system is being worked out to free the observer from this duty so that he can do other things, perhaps develop plates taken earlier.

In addition to keeping star maps up to date, proper-motion studies yield information on the rotation of our galaxy, the average brightness of stars, the exact value for the 26,000-year precession of the earth's axis and some idea of the distance to the center of the galaxy.

A second project going on at the same time is a study of stellar parallaxes. A star that is near enough to the earth will show an apparent change in position as the earth goes around its orbit, since earthlings will see the star at a progressively changing angle to the earth's orbital plane. Knowing the parallax and the diameter of the earth's orbit, one can calculate the distance to the star. In fact this is how the astronomer's favorite distance unit, the parsec, is defined. One parsec (from "parallax second") is the distance to a star that shows one second of arc apparent change in location over half the diameter of the earth's orbit (that is, over one astronomical unit). It works out to about 3.26 light-years.

The Lick project is using the observatory's 36-inch telescope to take a series of small plates (5 by 10 inches) and measure them for stellar parallax. Unlike the proper-motion studies, exposing the plates will take only two or three years. In the whole sky there are about 50,000 stars within a distance of about 50 parsecs. A star at 50 parsecs shows a parallax of 2/100 of a second of arc; the 50,000 includes stars from those with the largest parallaxes seen down to that level. In the northern sky that Lick can see the number is some fraction of 50,000. So far 6,000 have been measured, and small increments are continually added. So large is the job that they are concentrating, says Robinson, on stars of real interest to other astronomers.

—Dietrick E. Thomsen