

# physical sciences

## A cusp of plasma

In the past physicists attempting to confine plasmas of ions and electrons in work aimed at controlled thermonuclear fusion have paid little attention to magnetic fields with cusped shapes. Theory seemed to indicate that particles could easily escape from such fields.

New experimental and theoretical departures are encouraging a new look at cusped fields, Allen H. Boozer and M. A. Levine of the Air Force Cambridge Research Laboratories report in the Nov. 19 *PHYSICAL REVIEW LETTERS*. A cusped field can be produced by electric currents running in four wires parallel to each other in such a way that in

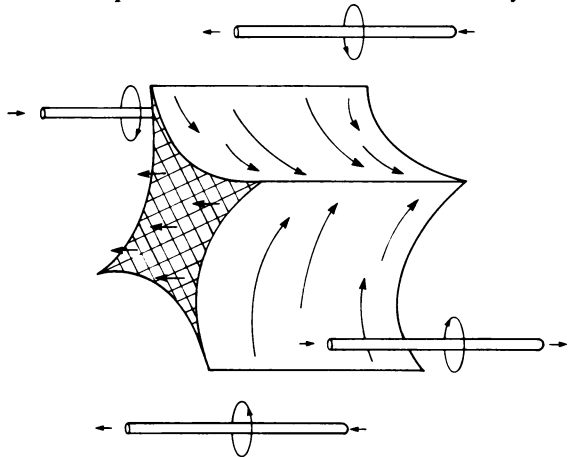

cross section they occupy the corners of a square. This produces a field that in cross section resembles a diamond with its sides curved inward. Levine and C. C. Gallagher did an experiment in which they held a plasma fairly successfully in such a field shape. New theoretical considerations by Boozer and Levine indicate that confinement good enough for controlled thermonuclear purposes may be achieved with such a cusped field bent in a toroidal shape especially if it is "stuffed" with another field perpendicular to the cusped field.

## Quasar-galaxy association

One of the best arguments that quasars are actually at the distance that the redshifts in their light would lead one to believe is to show instances where quasars are associated with galaxies of the same redshift. (Galaxies are assumed to be at their redshift distance since it is hard to imagine any nondistance effect that could provide a large part of their redshifts.) Up to now there were five such associations. Now in the Nov. 12 *NATURE PHYSICAL SCIENCES* Alan Stockton of the University of Hawaii presents a sixth, the association of quasar 4C37.43 with a faint nearby galaxy. The quasar's redshift is 0.370; the galaxy's, 0.3736.

## Quarks and proton scattering

The elastic scattering of protons against protons can be satisfactorily explained by a theory in which a proton is made of three quarks and scattering at low energies is dominated by interactions in which one quark in the incoming proton scatters off one quark in the target proton. At higher energies two-quark collisions dominate.

In the Nov. 19 *PHYSICAL REVIEW LETTERS* A. S. Kanofsky of Lehigh University and Brookhaven National Laboratory and K. F. Klenk of Lehigh find that this theory also works for inelastic proton-proton scattering.

# science education

## Good teaching pays off

Socrates questioned, medieval scholars "professed" and many a modern teacher just drones on, but good teaching *does* make a difference, according to a study conducted by Peter Frey of Northwestern University. Reporting in the Oct. 5 *SCIENCE*, Frey correlates performances of various sections of large mathematics classes to specific student rating factors of the instructors involved. Earlier studies seemed to show that when students were asked to rate their instructors on some nebulous quality, like "total teaching performance," the ratings correlated negatively with the grades the students received. Distrusting such a broad evaluation criterion, Frey devised a more detailed rating scheme. Students were asked to rate themselves, as well as their teachers, on such considerations as a sense of accomplishment ("This course has developed my ability to examine the evidence in this field") and teacher presentation ("The teacher communicated his ideas in a unambiguous manner").

Final examination scores for a class (corrected for chance variation) correlated highly with sense of accomplishment, teacher presentation and fairness of grading, and correlated somewhat less with work load, organization and planning and the teacher's accessibility to the student. Ratings assigned by individual students were independent of their own particular grade. Frey discovered another, unexpected correlation: "It would appear that there is a trade-off relationship between the clarity of an instructor's presentations and the work load he imposes on his students."

## Medical schools: Enrollment up

With medical school enrollment climbing almost 10 percent a year, the completion of six new schools this year, and 16 more in the planning and implementation stages, the business of medical education in the United States is booming as never before. But pressure of applicants to gain admission is rising even faster, reaching "critical proportions," according to an article in the Nov. 19 *JOURNAL OF THE AMERICAN MEDICAL ASSOCIATION*. A decade ago, about 16,000 persons sent in almost 60,000 applications to fill about 9,000 medical school openings. Today, 36,000 persons complete 267,000 applications to fill less than 14,000 positions. During that time, the percent of women enrolled has about doubled. The percentage of black students has more than doubled in the last three years. But competition is very keen—more than 95 percent of first-year students now have better than a 2.6 average, and almost a third have more than a 3.6 average (4 = A).

Faced with such a press of competition and enrollment pressure, some medical schools have begun encouraging their students to finish in three, rather than four years, while students unable to get into American medical schools are increasingly going abroad. Open admission of minority students has also led to complications: 12 percent of first-year black students had to repeat the year's course work, compared to one percent of first-year white students.

## No getting around grades

A survey of American universities by the American Council on Education shows that the trend to "pass/fail" credits may be self-defeating. When grade point averages are unavailable, graduate schools simply choose students more on basis of their standardized test scores and the prestige of their school.