

## Fatty acids found in two meteorites

Great interest was aroused in 1970 when amino acids were discovered inside certain meteorites. The discovery seemed to show that fairly complex organic compounds, and ones essential to life, could form by some chemical process apart from living organisms in the outer reaches of the solar system.

Now another class of chemicals related to life, fatty acids, has been discovered in meteorites. In samples of two carbonaceous meteorites (the Murray and the Murchison) Keith Kvenvolden of NASA's Ames Research Center and George U. Yuen of the University of Arizona found 17 varieties of fatty acids. The compounds are similar to those used by plants and animals to produce more complex biological molecules.

Theory suggests that these compounds were formed billions of years ago as the solar nebula was condensing to form the sun and planets. At times and places where the temperature was low enough the compounds were incorporated into carbonaceous chondrite meteors. The meteors then proceeded to bombard the earth. Even today dozens of tons of meteoritic matter a day strike the upper atmosphere. In the early days of the solar system, before the gravitational forces of the sun and planets had swept away most of the meteoritic debris, the bombardment must have been heavier. A ton of meteoritic matter would yield about a half-pound of fatty acids so after a while there would have been a good deal of organic matter lying around. "It may," says Kvenvolden, "have contributed directly to the origin of life on earth." □

## New telescope for molecular astronomy

The molecules found in the gas clouds of interstellar space radiate mostly in the millimeter-wave range of the radio spectrum. As the study of these molecules increases, there is a need for more telescopes specializing in the millimeter range. Plans for an instrument that will be the United States' most sensitive telescope in that range have been announced by the National Science Foundation and the University of Massachusetts. It will have a 45-foot-diameter dish-shaped aluminum reflector and will use a maser receiver for high sensitivity. The new telescope will be built at the Five-College Radio Astronomy Observatory, an institution in which the University of Massachusetts cooperates with four neighboring colleges, Amherst, Hampshire, Mt. Holyoke and Smith. □

february 2, 1974

*Skylab's gyros are mounted so that, in a pinch, they can double for one another in more than one axis. A single gyro, however, would need too much propellant if it had to work in all three axes.*

NASA

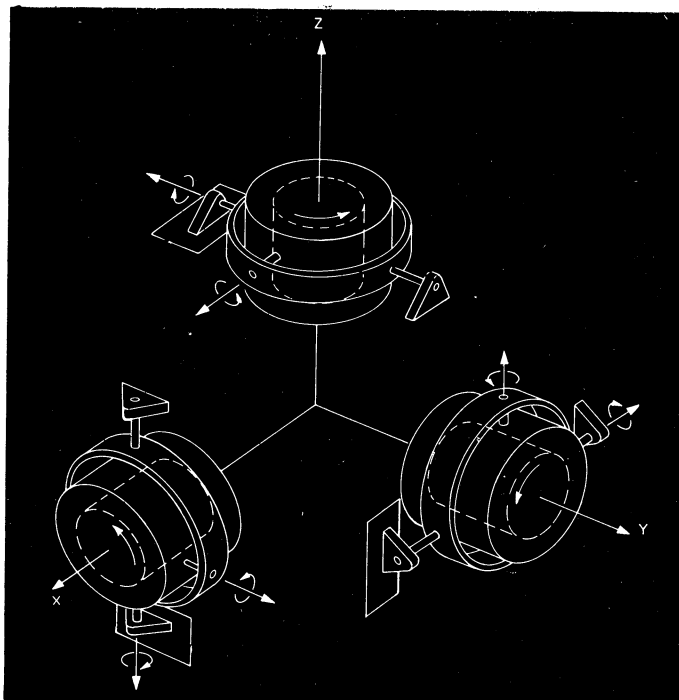

## Skylab 3 nears end of 84-day mission

After two months of uncertainty, NASA officials are finally agreed: Skylab 3 looks good to last out its full 84-day mission.

When the first of Skylab's main gyroscopes gave up the ghost and ground to a halt on Nov. 23 (SN: 12/1/73, p. 344), flight controllers on the ground didn't even wake up the sleeping astronauts to tell them about it. But several scientific experiments, such as photography of the comet Kohoutek and of earth's natural resources, were later delayed because of concern that the space station would use up too much propellant maneuvering with only two of its three gyros working. If a second gyro went out, there could be no more than three weeks of sharply curtailed activity before the Skylab crew would have to return to earth.

Then the second gyro began acting up.

The gyroscopes, 22 inches across and weighing 140 pounds, spin on shafts with low-friction bearings at each end. On four occasions before the first gyro failed, it slowed down about 100 to 150 revolutions per minute from its normal speed of just under 9,000 r.p.m., and the temperature difference between the two shaft bearings increased rapidly as much as 10.8 degrees F. from its normal level of between 60 and 80 degrees. The failure actually occurred while Skylab was out of radio contact with the earth, but just before contact was lost the temperature difference was

seen to rise by almost 100 degrees, suggesting some source of friction at one end of the shaft.

The second gyro has been far more erratic than the first, giving many observers a case of nerves about the future of the mission. On Jan. 23, it showed its thirty-third "glitch," despite the fact that for two weeks previously, flight controllers had been "hand-controlling" the bearing heaters to keep them in a narrower temperature range.

During the week of the thirty-third glitch, engineers from the Marshall Space Flight Center and Johnson Space Center met to compare notes on the problem. Theories abounded (lack of lubricant, leaks), as did proposed remedies (deliberate slowdowns, extra heat on both bearings, crossed fingers), but because the second gyro seemed to be stabilizing at its slower speed (it was still slow as of Jan. 29), the temporary decision was to leave it alone.

Banking on that stability, officials decided that, if the gyro does not become still more troublesome, the regular schedule of earth resources, solar and other observations would be followed, just as if nothing were wrong. The supply of propellants for changing the space station's orientation, a critical commodity in times of gyro worry, has been deemed "plenty," and the mission continues.

A milestone for the flight was the decision on Jan. 10 to grant the first of the week-at-a-time extensions beyond the originally planned 60 days. Two more followed, and the final extension was expected late this week. Splash-down is set for Feb. 8. □