

Stretching conceptions of chemical bonds

No one has directly observed a chemical bond, so scientists who try to envision such bonds must rely on experimental clues and their own imaginations.

The models resulting from these mental exercises provide windows onto chemical phenomena that might otherwise go unnoticed, and they help scientists predict how molecules might behave without actually making them. But the prevailing models can also hinder scientists from recognizing concepts or phenomena that don't fit into them, contends Richard P. Messmer, a physicist at General Electric's Research and Development Center in Schenectady, N.Y.

In the Jan. 16 *JOURNAL OF THE AMERICAN CHEMICAL SOCIETY*, Messmer argues that an unconventional bonding scheme, known as the generalized valence bond (GVB) theory, gracefully accounts for a class of molecules that conventional theories can't portray without slipping in counterintuitive concepts and adjustments.

Sulfur trioxide (SO_3) exemplifies these "hypervalent" molecules. The traditional picture of its bonds relies on the pre-1920 Lewis-Langmuir octet rule, which requires that eight electrons surround each of SO_3 's four atoms. This scheme portrays the molecule as a set of three equivalent

"resonant structures," each using a different oxygen atom to form a double bond with the sulfur atom while the other oxygen atoms form single bonds, for a total of four bonds.

In the 1930s, Linus Pauling developed the valence bond (VB) theory, reformulating the octet rule according to quantum mechanical principles. In this model, electrons occupy specific regions around atomic nuclei. When electrons on adjacent atoms pair up, they form a bond localized between the atoms. For hypervalent molecules, however, the VB portrait can become complicated and computationally cumbersome. Another widely applied model, called the molecular orbital (MO) theory, eases those computations, but only by including hard-to-visualize concepts such as bonding electronic orbitals that aren't confined between bonded atoms.

The GVB theory, developed more than 20 years ago by William A. Goddard III of Caltech in Pasadena, combines the computational ease of the MO theory with the conceptual clarity of the VB theory, Messmer says. In this scheme, SO_3 's sulfur atom forms six equivalent bonds, two with each oxygen atom, yielding a unique structure in which each bond comprises a pair of localized orbitals. There's no

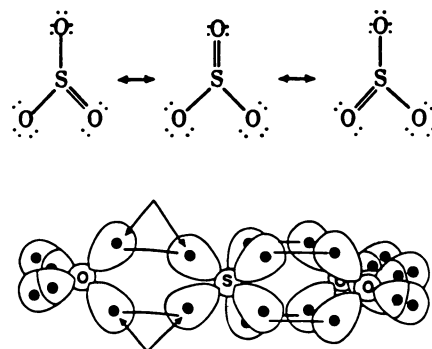

SO_3 bonding portrayed by resonant structures (top) and GVB model.

need to invoke resonant structures or "delocalized" orbitals, Messmer says.

The theory has gained few followers so far, but Goddard says he suspects that will change as chemists show that it can resolve seeming anomalies such as hypervalent molecules and can yield useful predictions about other types of chemical behavior. Goddard, Messmer and others are now working to demonstrate just that.

"These [GVB concepts] really are extensions of old ideas," Messmer says. "By adding flexibility, we can describe things more simply. And that should allow people to think about molecules in a new way."
— I. Amato

Cancer war escalates to genetic weapons

Two terminally ill cancer patients this week received infusions of genetically engineered white blood cells designed to attack their intractable tumors, marking the first attempt to use gene therapy against cancer, federal scientists announced. The event comes four months after the first human gene therapy experiment, in which researchers added a missing gene to the blood cells of a child suffering from a deadly immune deficiency (SN: 9/22/90, p.180).

Both cancer patients — a 29-year-old woman and a 42-year-old man — have advanced melanoma, a deadly form of skin cancer that had failed to respond to traditional therapies. The experimental approach, which received the final go-ahead from the Food and Drug Administration on Jan. 8, seeks to enhance the tumor-fighting power of the patients' own white blood cells by boosting production of tumor necrosis factor (TNF), a potent cancer-shrinking compound normally secreted in small quantities by those cells. The work is led by Steven A. Rosenberg, R. Michael Blaese and W. French Anderson of the National Institutes of Health in Bethesda, Md.

Several weeks ago, the researchers removed white blood cells called tumor-infiltrating lymphocytes from

each patient's tumors. These cells naturally home in on tumors but often lack the power to kill them. The team cultured the lymphocytes in the laboratory, mixing them with partially disabled viruses loaded with extra copies of the TNF gene. The viruses acted as delivery trucks, dropping their TNF-gene packages into the lymphocytes' DNA. This week, after tests showed that the cultured cells had incorporated the TNF genes, the researchers returned the cells to the patients.

"This is an attempt to use genetic techniques to improve medical treatment for cancer patients," says Rosenberg. He adds, however, that "it's going to be a long time" before researchers refine the technique into a commonly available treatment with predictable results. Rosenberg spearheaded the four-year effort that led to federal permission to try the novel therapy on 50 patients.

He and his colleagues remain uncertain whether the current experiment will elicit therapeutic effects. This week's starting infusions of 100 million cells into each patient represent one-tenth the dosage initially proposed by Rosenberg. But FDA regulators, concerned about TNF's potentially toxic

effects, limited the number of cells per infusion and disallowed the concurrent infusion of interleukin-2, which the researchers had wanted to add to their experimental cocktail. Interleukin-2 increases TNF secretion in cells bearing the TNF gene and increases their survival in the body. Without it, the engineered cells "don't proliferate and will die off fairly quickly," says Jay Greenblatt of the National Cancer Institute's drug regulatory affairs section.

The gene-altered cells produce less TNF than some nonengineered cells used in other cancer treatments. But if all goes well, additional infusions will boost patients' TNF levels significantly. The researchers have permission to pack larger and larger numbers of engineered cells into the twice-weekly infusions, Rosenberg says. Moreover, the experiment's protocol allows for the addition of some interleukin-2 later in the trials, depending on initial TNF-toxicity findings.

Rosenberg says he and his colleagues continue to look for particular subtypes of tumor-infiltrating lymphocytes that migrate to tumor sites more efficiently than others. By adding the TNF gene only to the more efficient subtypes, they hope to increase TNF's anticancer effects while minimizing its toxicity to healthy tissues.
— R. Weiss