

## Building and Flying Model Airplanes

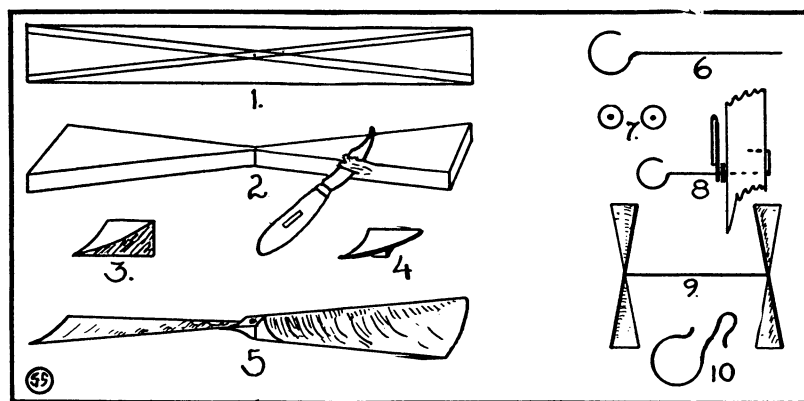

### Making the Power Plant

This is the second of a series of articles by Paul Edward Garber, telling how to make model airplanes. Mr. Garber is in charge of Aeronautics at the Smithsonian Institution.

The power plant of an airplane is a vital part. When I was in the Aerial Mail Service in 1918-19 one of the fellows said: "You can fly with a barn door if you have enough power." That statement was not quite true but it illustrates the fact that the engine and propellers are mighty important.

For our model we will use rubber bands for the engine and for our propellers we will use blades carved from wood. Propellers are interesting things. As a means for propulsion air propellers are older than water propellers. The famous Italian artist and engineer Leonardo da Vinci made an aerial propeller way back in the fifteenth century before America was discovered, whereas John Stevens of this country was the first to adopt the screw propeller for steamboats a generation after the United States became a republic.

Many kinds of air propellers have been invented. Da Vinci's looked like a spiral staircase covered with cloth. The most modern kinds are thin knife-like blades made of steel. For our model we will adopt a kind that is easy to make, and we will follow the pattern of Samuel Pierpont Langley, who developed the first airplane in the history of the world to make a sustained flight under its own power. His airplane was 14 feet span, too small to carry a man, but it showed that flight was possible. That was way back in 1896. His airplane flew nearly a mile with propellers like these. I hope your model will fly as far. Perhaps it will.

The following material is needed for the power plant:

- 2 propeller blanks, pine wood, 8" x 1 1/4" x 3/4".
- 2 hatpins.

4 No. 16 washers or dress spangles.  
48 feet of 1/8" flat rubber thread,  
or of linked rubber bands.

We will use two propellers, one turning the way a clock goes, and the other turning left-handed, both are to blow the air away from the model. For material procure two blocks of wood, 8" long, 1 1/4" wide and 3/4" thick. On the ends make a mark 1/4" from the sides. On the top, draw lines from these marks to the opposite corners, as shown in the drawing. Now, saw from the corners to the center, and when all four cuts have been made you will have a shape like that shown in Figure 2. Next drill a hole in the exact center. This can best be done with the drill you used for the bearings, but as a substitute you can use the hatpin heated red hot. When the hole is made balance the propeller blank. Make sure that it swings level. If it does not, cut away the heavy side until it does. After it is balanced, commence carving out the blades. Begin as shown in Figure 3, and cut away that face from the left top edge to the right lower edge, cutting more in the center so as to slightly cup the blade as illustrated in the end view Figure 4. Cut both blades, and then again balance the propeller. Next turn it over, and cut the backs of the blades. They should be made thin, so that as you hold them up to a light you can see a slight pinkness. Make the blades gradually thicker toward the hub, but have them of uniform thinness for the outer two-thirds of the blade as shown in the end view of the finished blade, Figure 5. When both backs are cut again balance the blade, taper off the hub, and smooth the blades with sandpaper. The left-handed propeller is cut in the same manner, but when starting cut on the left side of the blank, from the right top edge to the left lower edge. This

(Just turn the page)

### A Wineglassful of Brains

A wineglassful of brains—a very small wineglassful—is all that separates the average intelligent man from the fool and the social misfit.

So declares Prof. C. Wingate Todd of Western Reserve University. To be scientifically accurate, the intelligent and successful man averages 1500 cubic centimeters, or a little more than three pints, inside his cranium, while the unintelligent down-and-outer runs about 1480 cubic centimeters. The wide difference in results, he remarks, is obviously a matter of the quality rather than the quantity of these last few spoonfuls of gray matter.

Writing in *Science*, Prof. Todd tells of a grim sort of skull barometer of hard times and prosperity which he and his associates have kept for several years, using the cadavers of unknown paupers turned over to the medical school by the public authorities of Cleveland:

"The average among Cleveland's social ineffectives from 1913 to 1917 was quite constantly within 10 cubic centimeters of 1,480 cubic centimeters. This difference made no impression upon us until in 1918 a strange thing happened. Our average fell to 1,410 cubic centimeters. Now during that year none but the veriest fool was left destitute: the others were all in the army or earning good wages in civilian life. But in 1919 when, after the armistice, industrial stagnation set in and threw out of work many who had recently found jobs; and when, moreover, the disbanding army disgorged a glut of men upon a society which could not immediately absorb them, the average brain volume of our social failures rose to 1,520 cubic centimeters.

"That looked serious to us and  
(Just turn the page)

METEOROLOGY

### Size of Raindrops

A raindrop that falls on your nose is probably so small that three hundred and twelve of them laid side by side only make an inch. At least this is true of the average Irish raindrops.

The measurements were made by J. J. Nolan and J. Enright, both of University College, Dublin. A total of 3,026 drops were measured and more than 180 were 1/312 of an inch in diameter. The largest, of which less than 20 were found, were about ten times this diameter.

Science News-Letter, August 13, 1927

### Wineglassful of Brains

(Continued from page 101)

with great interest we read the prognosis of bankers and captains of industry regarding the future. According to prediction the situation improved in 1920 and our mean brain volume sank once more to near the pre-war level. But the feeling of satisfaction soon gave place to apprehension, for the second and much worse industrial depression set in, distress growing steadily more acute during the months of 1921. Day by day, like obscene demons from the pit itself, we chalked up the rising score until it reached the appalling level of 1,550 cubic centimeters.

"Here was a new class of men entering our portals and they came by a different route. Here were the men who could think for themselves, who knew and resented their fate. The pneumonia of the shiftless, the tuberculosis of the over-wearied struggler, the heart disease of the adventurer no longer acted alone as our receiving agents. Instead men shot themselves, or each other, threw themselves into the lake; poisoned themselves with morphine or raisin jack; perished of cold, listlessly lost in despair.

"And then, suddenly as it had begun, these expectant ghouls in anatomy saw the barometer of brain volume begin to fall, steadily, steadily down. Relief had come: though it was not apparent to the city we knew the end was in sight. Hope was restored again in those whose nervous systems had been shattered by defeat. Never again have we seen the like. Slight fluctuations from year to year and an average somewhat above the pre-war mean have been our lot but never that alarming rise which we experienced in the year of intense depression."

Science News-Letter, August 13, 1927

Isa Lake, in Yellowstone National Park, in the spring sends part of its waters to the Pacific Ocean and part to the Atlantic.

Martin Johnson, well known African explorer, plans to return to the Congo for the chief purpose of photographing gorillas.

Plans are being formed to build a new international bridge across the St. Lawrence River at the eastern end of Lake Ontario.

### Model Airplanes

(Continued from page 101)

balancing is very necessary; the blades should balance level and the two propellers should weigh the same and be the same shape and size throughout. If this is done and all other factors are true the model will fly straight.

The propeller shafts are bent from the stiff wire of the hatpin to the shape shown in Figure 6. The hook must be round and in line. In other words, when the shaft is twirled between the thumb and finger, the hook must look like a circle and not like an egg. If the wire is too stiff to bend or if it snaps off when bent, it must be heated red hot and allowed to cool, after which it will be softer and more easily worked. When the shafts are made, insert them in the propeller hubs and turn the end back into the hub to secure it as shown in Figure 8. Figure 7 shows two washers to be used to reduce friction between the propeller and its bearing. They can be bought at hardware stores and are shown as number 16 washers. Dress spangles will do also. There may be some of these in your house on an old dress, or if not, notion stores carry them. Two of these are put on each shaft, after which the shafts are put through the bearings as shown in Figure 8. Figure 9 shows how the two propellers are put on the frame. The right handed one goes on the right side and the left handed one on the other. This arrangement makes the model fly highest because the down stroke of the propellers being outside exerts the most leverage. Figure 10 shows a fitting known as an "S" hook. Two of these are required, and are made from hatpins or other stiff wire to the shape shown. They are used to fasten the rubber strands to the nose hook.

Divide the 48 feet of rubber into two lengths. Tie the ends of these lengths together making two large rubber hoops. Loop these hoops twice, forming two hanks of eight loops each. To one end of each loop attach an "S" hook. Pass the other end through the cans on the frame and hang it onto the propeller shaft hook. Put the "S" hook on the nose hook. This completes the power plant.

Next week we will start on the wing.

Science News-Letter, August 13, 1927

Clothes moths do not feed on cloth of vegetable origin, such as cotton or linen.

# Tune In

## On Our Science Radio Talks!

In cooperation with leading broadcasting stations, Science Service presents a weekly radio talk on "SCIENCE NEWS OF THE WEEK"

These are given from the following stations:

KOAC	Oregon Agricultural College, Corvallis, Oregon.
KUOK	University of Arkansas, Fayetteville, Ark.
WABC	Atlantic Broadcasting Corp., New York, N. Y.
WEAO	Ohio State University, Columbus, Ohio.
WBAO	James Millikan University, Decatur, Ill.
WBET	Boston Evening Transcript, Boston, Mass.
WCAD	St. Lawrence Univ., Canton, N. Y.
WDBO	Rollins College, Winter Park, Fla.
WDOD	Chattanooga Radio Company, Chattanooga, Tenn.
WEBW	Beloit College, Beloit, Wisc.
WGR	Federal Radio Corp., Buffalo, N. Y.
WHAS	The Courier-Journal, Louisville, Ky.
WHAZ	Rensselaer Poly. Inst., Troy, N. Y.
WMAL	The Washington Radio Forum, Washington, D. C.
WMAQ	Chicago Daily News, Chicago, Ill.
WOO	John Wanamaker, Philadelphia, Pa.
WRAV	Antioch College, Yellow Springs, Ohio.

Watch the program of the station nearest you to see what time these talks are given. If no station near you gives them, write us, suggesting any station that you think might give them.

SCIENCE SERVICE  
21st & B Sts.  
Washington, D. C.