

# Building and Flying Model Airplanes

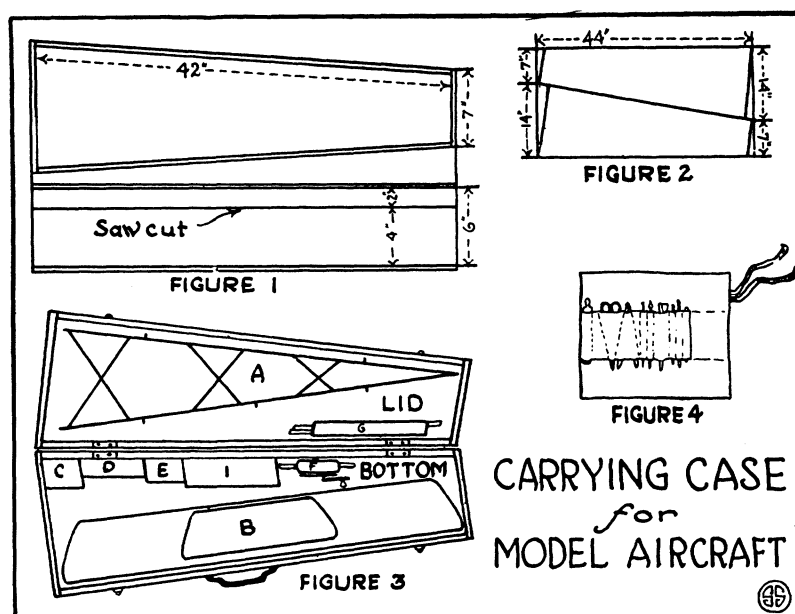

No. 16

This is the eleventh of a series of articles by Paul Edward Garber, telling how to make model airplanes. Mr. Garber is in charge of aeronautics at the Smithsonian Institution.

## An Airplane Carrying Case

A model airplane when completed is a constant source of happiness to its maker, either when in the air demonstrating its abilities, or when displayed at home, to show one's handiwork. During its construction, and when carrying it to the flying field, however, it is best to keep it protected and enclosed. This is best done through use of a model box. Practically all model flyers have one and as they are easily made, you should follow their example. Procure the following materials:

- 1 board of white pine, 9 ft. x 6 in. x  $\frac{1}{2}$  in.
- 1 piece compo board, or other wallboard, 44 in. x 21 in.
- 2 butt hinges,  $1\frac{1}{2}$  in. x  $\frac{1}{2}$  in.
- 2 fasteners, such as are used on handbags.
- 1 drawer handle, with open loop.
- 2 doz.  $\frac{1}{4}$  in. screw eyes.
- 6 yards  $\frac{1}{2}$  in. tape.
- Screws, nails, paint.

After squaring the ends of the board, cut from it two pieces forty-two inches long, one piece seven inches long, and one piece fourteen inches long. Plane the ends of the two forty-two-inch pieces to a slight angle so they will make a snug fit when the frame is nailed together by fastening the two pieces at the ends, as shown in the drawing. Next cut the wallboarding in the manner illustrated in the drawing, and nail these as sides onto the frame. Use glue in all the joints of the frame,

and for nailing on the sides use flat head nails about No. 14, 1 inch long. Finishing nails should be used for nailing up the frame. In order to form the lid and lower section, cut the box in half, along a line drawn about two inches from a side. Plane and true up the rough edges left by the saw, and while you hold the two sides together, mark the place for the hinges and fasteners. Slightly indent the hinges into the back edges, in order that the completed box may fit snugly together. If handbag fasteners are difficult to get, ordinary window catches may be substituted, or even common screen door hooks will do as a last resource. The model box should next be painted or covered with imitation leather on the outside, and shellaced or painted inside. Its handiness may be greatly increased if spaces are provided for various spare parts, and tools. The drawing suggests an interior arrangement. A is the model fuselage held in the lid, B is the wings, C a can containing the rubber strands used for power; incidentally the rubbers should be well powdered with soapstone or talcum powder to preserve them. D is a box for small fittings, adhesive, rubber bands, etc., E a roll of tools for making repairs on the field, F is a winder held in place by a cleat or strap, G is a bundle of sticks and fabric for repairs and H shows a spool of wire and thread, fastened together on a short stick, and held in the corner by an elastic band. When the model box has been loaded to the condition that it will be used for traveling,

find the balancing point and attach the handle to the top. Many makers delight in decorating their model boxes neatly with their Model insignia, or their own monogram. Nickel or brass corners, such as valise makers use, make the box more durable and attractive.

Figure 4 shows a tool roll which may be easily made from a piece of cloth. A center strip is stitched to leave pockets for tools and a flap is left at each side and the end for covering the tools, with tapes for tying it up.

When the model maker decides to attend distant model contests a box such as this is a necessity, but regardless of such use, it is always a convenience.

Science News-Letter, October 29, 1927

GENERAL SCIENCE

## Why Not Look?

In the year of our Lord 1432, there arose a grievous quarrel among the brethren over the number of teeth in the mouth of a horse. For thirteen days the disputation raged without ceasing. All the ancient books and chronicles were fetched out, and wonderful and ponderous erudition, such as was never before heard of in this region, was made manifest. At the beginning of the fourteenth day, a youthful friar of goodly bearing asked his learned superiors for permission to add a word, and straightway, to the wonderment of the disputants whose deep wisdom he sore vexed, he beseeched them to unband in a manner coarse and unheard-of and to look in the open mouth of a horse and find answer to their questionings. At this, their dignity being grievously hurt, they waxed exceedingly wroth; and, joining in a mighty uproar, they flew upon him and smote him hip and thigh, and cast him out forthwith. For, said they, surely Satan hath tempted this bold neophyte to declare unholy and unheard-of ways of finding truth contrary to all the teachings of the fathers. After many days more of grievous strife the dove of peace sat on the assembly, and they as one man, declaring the problem to be an everlasting mystery because of a grievous dearth of historical and theological evidence thereof, so ordered the same writ down. —Quoted in *Science Progress* as accredited to Francis Bacon.

Science News-Letter, October 29, 1927

Aviators are investigating flying conditions through Africa to test the practicability of an air route from Capetown to Cairo.